

WHISPERSOG 3.0 FM

(83.102)

Voltage	(V)	400	Filter surface	(m ²)	2
Motor	(kW)	3,0	Quantity of filter	(pc)	1
Ampere	(A)	4,5	Filter material	dust classification „M“	
Rated frequency	(Hz)	50	Filter cleaning	manual	
Fuse	(A)	16	Weight	(kg)	120
Max. neg. pressure	(Pa)	31.500	Intake	(mm)	50
Max. airflow	(m ³ /h)	216	Dust collection bin	(liter)	80
			Dimensions (L x W x H)	(mm)	1.300 x 640 x 1.250

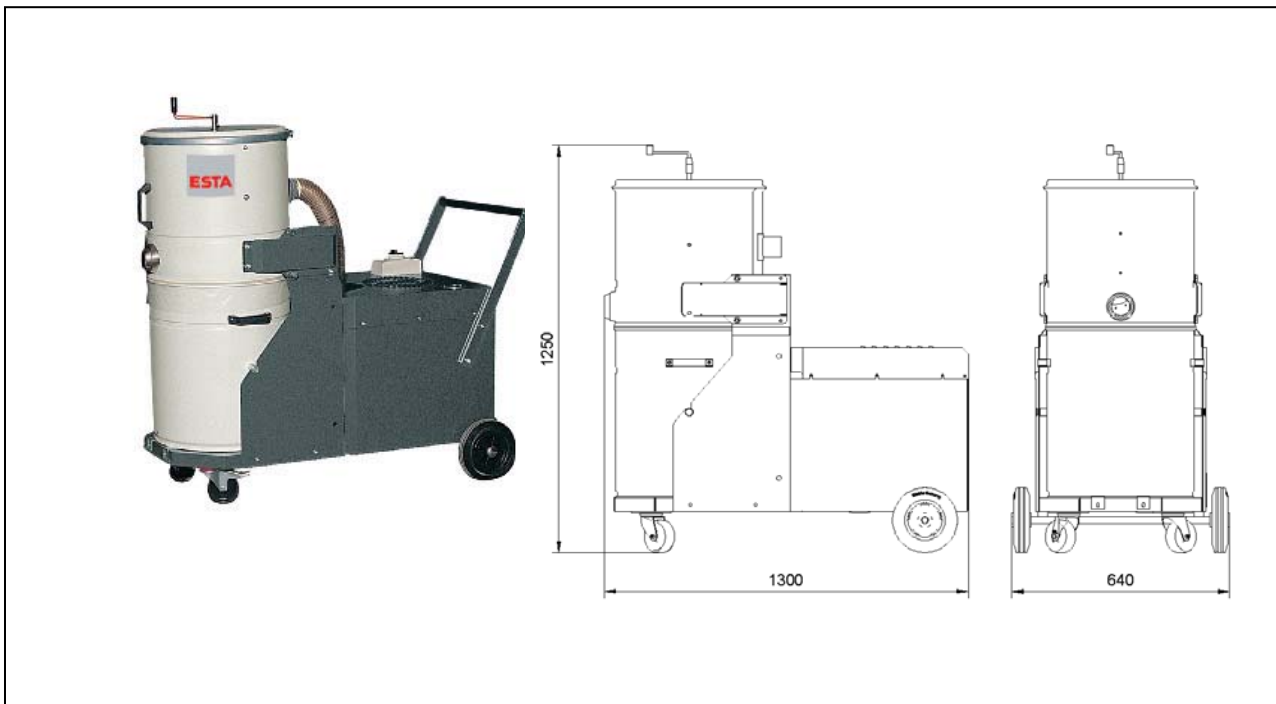

ESTA PLUS

Application range:

Removal of coarse, fine and pourable dust during cleaning works

Characteristics:

Filter cleaning: manual brush cleaning mechanism

Your benefits at a glance:

Very quiet and powerful vacuum cleaner for dry dust
Designed for continuous operation
Cleanable long life cartridge filters with dust classification M
Easy disposal of the dust collection bag by a patented tiltable filter housing

Modification:

With different filter cartridges
Special voltage
Special painting
Installation of a pre-separator possible

State of the art: 83102-51-00 Subject to change without notice! For remaining questions please do not hesitate to contact us.