

# WHISPERSOG 2.2 FM

(83.101)

Voltage	(V)	400	Filter surface	(m <sup>2</sup> )	2
Motor	(kW)	2,2	Quantity of filter	(pc)	1
Ampere	(A)	5,6	Filter material	dust classification „M“	
Rated frequency	(Hz)	50	Filter cleaning	manual	
Fuse	(A)	16	Weight	(kg)	105
Max. neg. pressure	(Pa)	21.000	Intake	(mm)	50
Max. airflow	(m <sup>3</sup> /h)	300	Dust collection bin	(liter)	80
			Dimensions (L x W x H)	(mm)	1.300 x 640 x 1.250

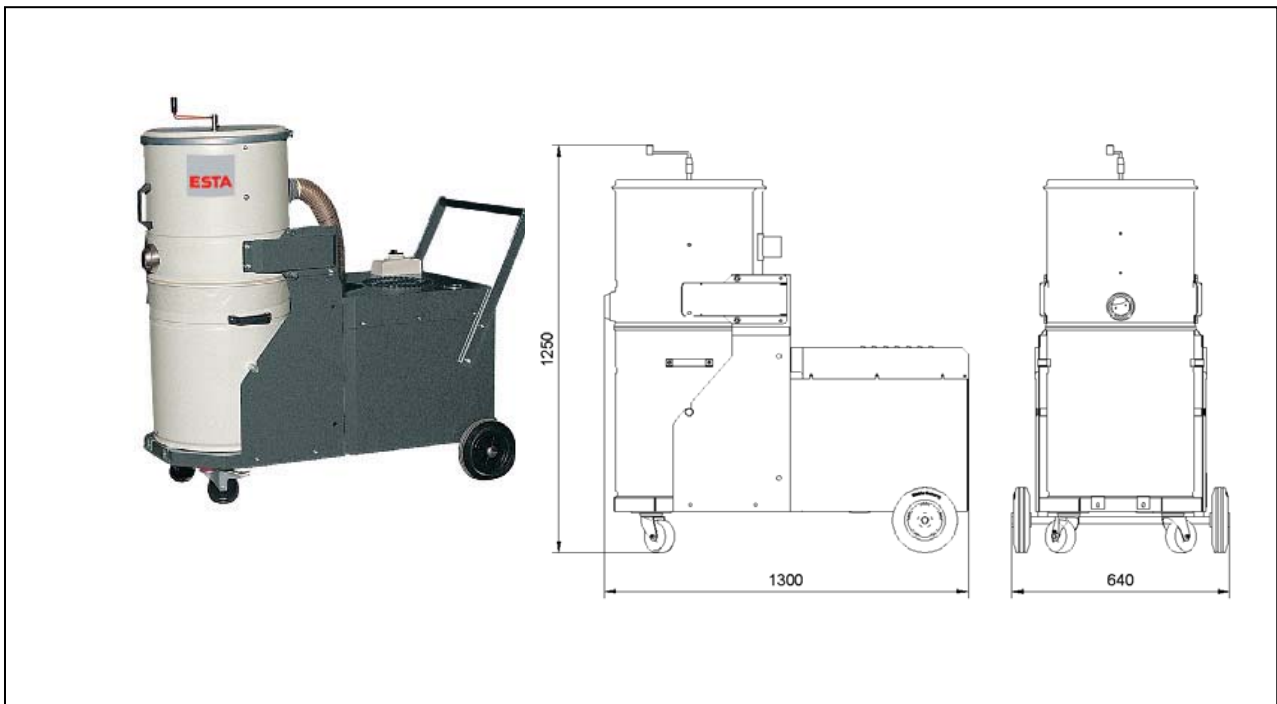

## ESTA PLUS

### Application range:

Removal of coarse, fine and pourable dust during cleaning works

### Characteristics:

Filter cleaning: manual brush cleaning mechanism

### Your benefits at a glance:

Very quiet and powerful vacuum cleaner for dry dust  
Designed for continuous operation  
Cleanable long life cartridge filters with dust classification M  
Easy disposal of the dust collection bag by a patented tiltable filter housing

### Modification:

With different filter cartridges  
Special voltage  
Special painting  
Installation of a pre-separator possible

State of the art: 83101-51-00 Subject to change without notice! For remaining questions please do not hesitate to contact us.