

Wet separator NA-1.1

(45.611)

Voltage	(V)	400	Water outtake	G ¾"
Motor	(kW)	1,1	Intake	(mm) 100
Current (400V/50Hz)	(A)	2,4	Weight (without Water)	(kg) 140
Fuse	(A)	16	Water capacity	(liter) ca. 35
max. neg. pressure	(Pa)	1.700	Dimensions (l x w x h)	(mm) 1.310 x 530 x 1.550
max. airflow	(m³/h)	560		

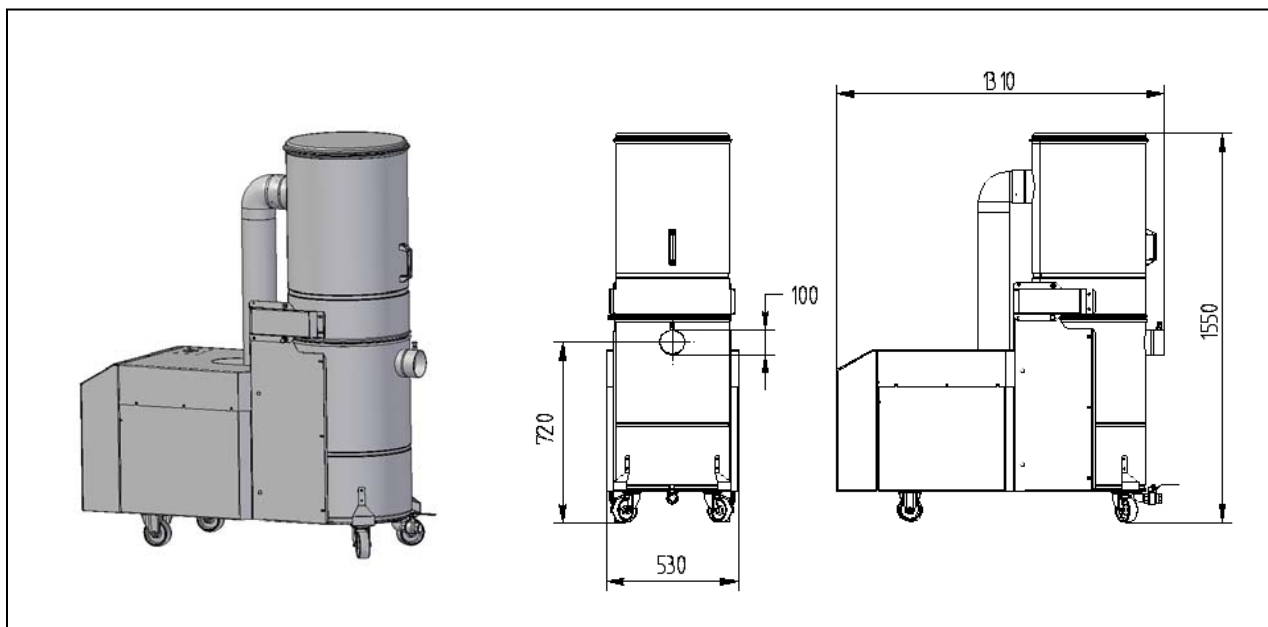

ESTA PLUS

Application range:

Extraction of sticky substances
Spark generating production processes
Extraction of flammable, explosive and try substances
defined as "Zone 22" types of dust

Your benefits at a glance:

Extraction of aluminium dust

High suction power for sticky and wet dust
For spark generating production

Special Features:

Tilt back upper housing
Magnetic valve for automatic water supply (optional)
Stainless steel (optional)
Optional in ATEX

State of the art: 45611-51-01 Subject to change without notice! For remaining questions please do not hesitate to contact us.