

NA-K 1800 B

(45.182)

Voltage	(V)	400	Water capacity	(Liter)	290
Motor	(kW)	4,1	Water connection		G ¾"
Current (400V/50Hz)	(A)	8,5	Intake / Outlet diameter	(mm)	180/280
Fuse	(A)	20	Weight (without water)	(kg)	340
max. negative pressure	(Pa)	4,300	Dust collection bin	(Liter)	50
max. airflow	(m ³ /h)	2,160	Dimensions (l x w x h)	(mm)	800 x 800 x 2,920

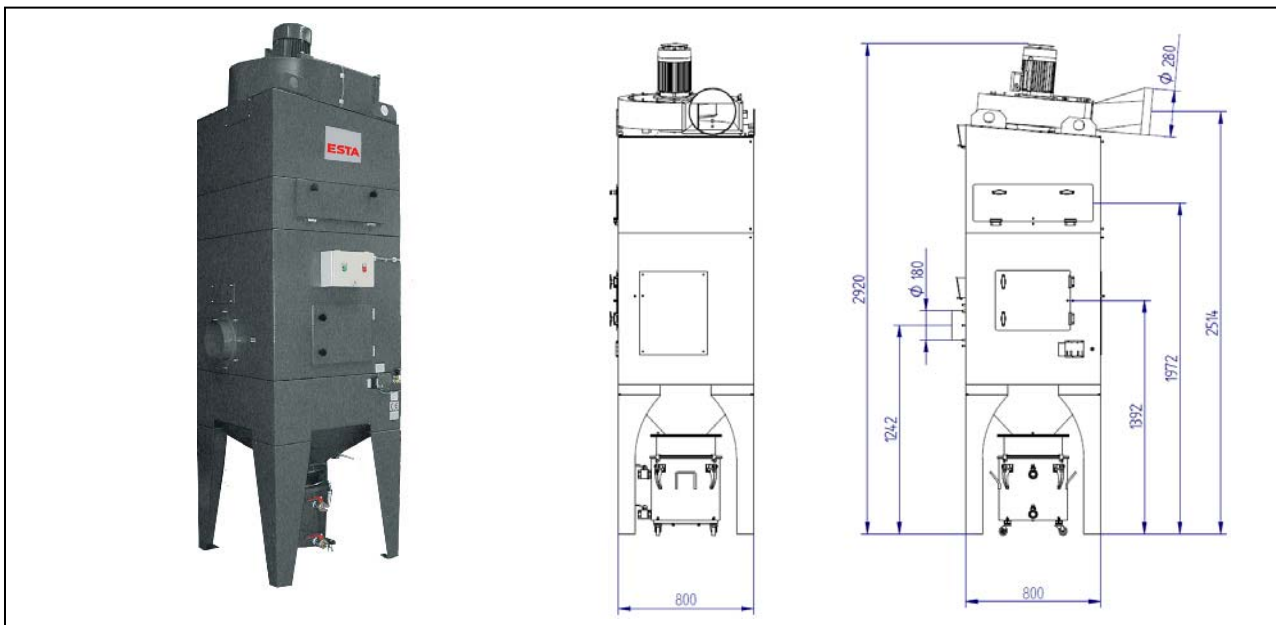

ESTA PLUS

Application range:

Extraction of aluminium dust
Dust extraction at individual or multiple workstations of adhesive and moistly dusts, especially metallic dusts that are sparks generating
As central exhaust station with intercepting pipe and several extraction points

Your benefits at a glance

High suction power for adhesive and moistly dusts
Ideal solution for sparks generating applications

Characteristics:

Partially made of stainless steel, epoxy resin based interior coating
Integrated control cabinet

Optional with special painting

State of the art: 45182-51-04 Subject to change without notice! For remaining questions please do not hesitate to contact us.