

DUSTOMAT-16M / 230 V

(09.420)

Voltage	(V)	230	Filter surface	(m ²)	9.4
Motor	(kW)	1,3	No. of filter elements	(pc)	1
Ampere	(A)	7,5	Filter material	Polyester „M“	
Rated frequency	(Hz)	50	Filter cleaning	manual pneumatically	
Fuse	(A)	16	Weight	(kg)	110
Max. neg. pressure	(Pa)	2.000	Intake	(mm)	125
Max. airflow	(m ³ /h)	1.140	Dust collection bin	(Liter)	45
Comp. air connection	(inch)	¼"	Dimensions (l x w x h)	(mm)	1.150 x 670 x 1.470
Sound level	(dB (A))	73			

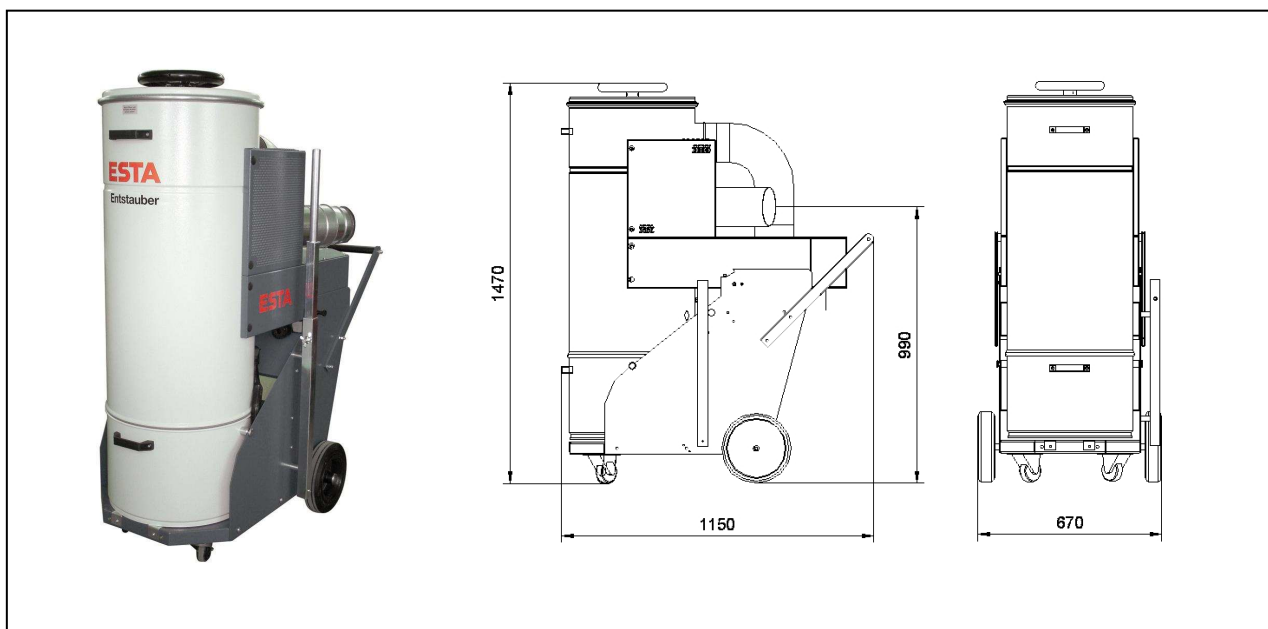

ESTA PLUS

Application range:

Dust extraction at individual workstations or machines
Pourable dust including hazardous types of dust

Your benefits at a glance

Low operating costs resulting from cleanable long life filter cartridges
Mobility combined with high extraction performance
Tilt-back filter housings for easy dust disposal
Suitable for most types of dust
Optional test certificate for specialized applications

Characteristics:

Filter cleaning method: manual pneumatically
Cleanable long life cartridge filter (dust classification M)
Test Certificate dust classification „M“
Equipped with volume stream control and acoustic signal transmitter
Special equipment with different filter cartridges, special voltage, special painting

State of the art: 09420-51-01 Subject to change without notice! For remaining questions please do not hesitate to contact us.